

Laboratory 8

Operational Amplifier Circuits (modified from lab text by Alciatore)

Required Components:

- 1x 741 op-amp
- 2x 1k Ω resistors
- 4x 10k Ω resistors
- 1x 100k Ω resistor
- 1x 0.1 μ F capacitor

Optional Components:

- LM224 Quad op-amp
- 2x 2k Ω resistors
- 1x 5 or 10k Ω pot

Objectives

The operational amplifier is one of the most commonly used circuit elements in analog signal processing. Because of their wide range of applications you should become familiar with the basic terminal characteristics of operational amplifiers and the simple, yet powerful circuits that can be built with a few additional passive elements.

In this laboratory exercise you will examine a few of the electrical parameters that are important in the design and use of circuits containing operational amplifiers. These parameters will illustrate how the real operational amplifier differs from the ideal op amp that we have discussed in class. These parameters are:

1. the input impedance
2. the output voltage swing
3. the slew rate
4. the gain-bandwidth product

Also during this laboratory exercise you will construct and evaluate the performance of the following operational amplifier circuits:

1. a non-inverting amplifier
2. an inverting amplifier
3. a voltage follower
4. an integrator
5. a differential amplifier.

Laboratory 8: OpAmps

Figure 8.1 represents the basic model for an amplifier. The model assumes a differential input, an input impedance between the two input connections, and a dependent voltage source with gain A and series output impedance. This model can be used to develop the terminal characteristics of an operational amplifier.

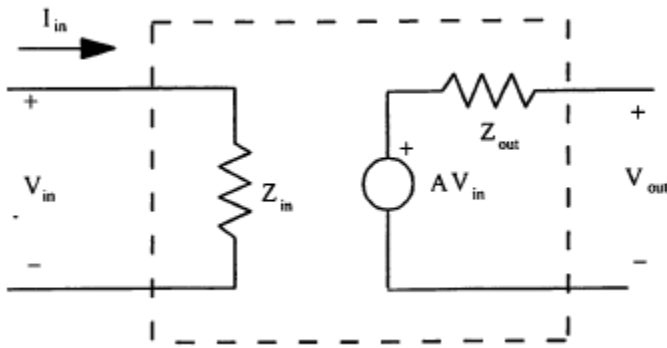

Figure 8.1 Amplifier Model

First, let the input impedance approach infinity and note what happens to the input current I_{in} ,

$$Z_{in} \rightarrow \infty \Rightarrow I_{in} \rightarrow 0 \quad (1)$$

Thus, an ideal operational amplifier, assumed to have infinite input impedance, draws no current.

Now, let the gain A of the dependent source approach infinity as the output voltage (V_{out}) remains constant and note what happens to the input voltage V_{in} ,

$$A \rightarrow \infty \Rightarrow V_{in} \rightarrow 0 \quad (2)$$

When an ideal operational amplifier, assumed to have infinite gain, is used in a circuit with negative feedback, the voltage difference between the input terminals is zero.

These ideal terminal characteristics greatly simplify the analysis of electrical networks containing operational amplifiers. They are only approximately valid, however.

Real operational amplifiers have terminal characteristics similar to those of the ideal op amp. They have very high input impedance, so that very little current is drawn. At the same time, there is very little voltage drop across the input terminals. However, the input impedance of a real op amp is not infinite and its magnitude is an important terminal characteristic of the op amp. The gain of a real op amp is very large (100,000 or above), but not infinite.

Another important terminal characteristic of any real op amp is related to the maximum output voltage that can be obtained from the amplifier. Consider a non-inverting op amp circuit with a gain of 100 set by the external resistors. For a one volt input you would expect a 100 V output. **In reality, the maximum voltage output will be about 1.4 V less than the supply voltage to the op amp (V_{cc}) for infinite load impedance.**

Laboratory 8: OpAmps

Two other important characteristics of a real op amp are associated with its response to a square wave input. Ideally, when you apply a square wave input to an op amp you would expect a square wave output. However, for large input signals at high frequencies, deviations occur. The response of an op amp to a high frequency square wave input is shown in Figure 8.2.

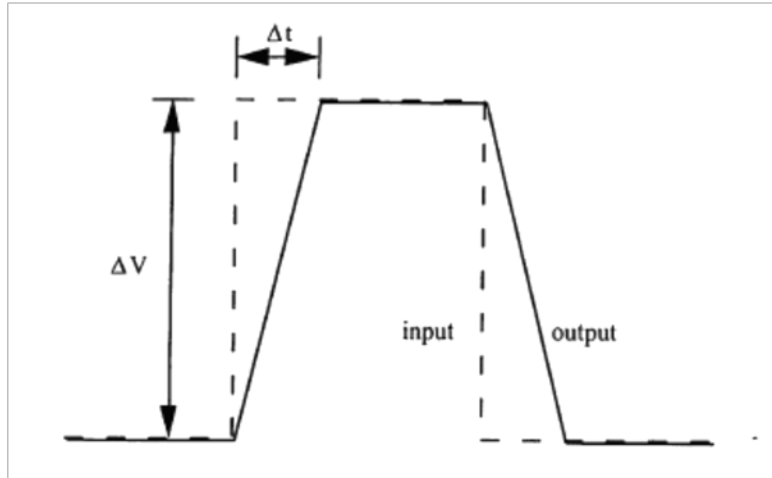

Figure 8.2 Effect of Slew Rate on a Square Wave

In order to quantify the response shown above, two operational amplifier parameters are defined:

Slew Rate: The maximum time rate of change of the output voltage

$$SR = \left(\frac{\Delta V}{\Delta t} \right)_{max} \quad (3)$$

Rise Time: The time required for the output voltage to go from 10% to 90% of its final value. This parameter is specified by manufacturers for specific load input parameters.

Another important characteristic of a real op amp is its frequency response. An ideal op amp exhibits infinite bandwidth. In practice, real op amps have a finite bandwidth which is a function of the gain set by external components. This gain is called the closed loop gain.

To quantify this dependence of bandwidth on the gain another definition is used, the Gain-Bandwidth Product (GBP). The GBP of an op amp is the product of the open loop gain and the bandwidth at that gain. The GBP is constant over a wide range of frequencies due to the linear relation shown in the log-log plot in Figure 8.3. The curve in the figure represents the maximum open loop gain of the op amp (where no feedback is included) for different input frequencies. The bandwidth of an op amp circuit with feedback will be limited by this open loop gain curve. Once the gain is selected by the choice of feedback components, the bandwidth of the resulting circuit extends from DC to the intersection of the gain with the open loop gain curve. The frequency at the point of intersection is called the fall-off frequency because the gain decreases logarithmically beyond this frequency. For example, if a circuit has a closed loop gain of 10, the fall-off frequency would be approximately 100,000 (10^5).

Laboratory 8: OpAmps

Figure 8.4 shows the pin-out diagram and schematic symbol from the LM741 Op Amp datasheet. Tables 8.1 and 8.2 shows some of the important electrical specifications available in the datasheet. The complete datasheet can be at manufacturer websites (e.g., Texas Instruments LM741 is at <http://www.ti.com/lit/ds/symlink/lm741.pdf>).

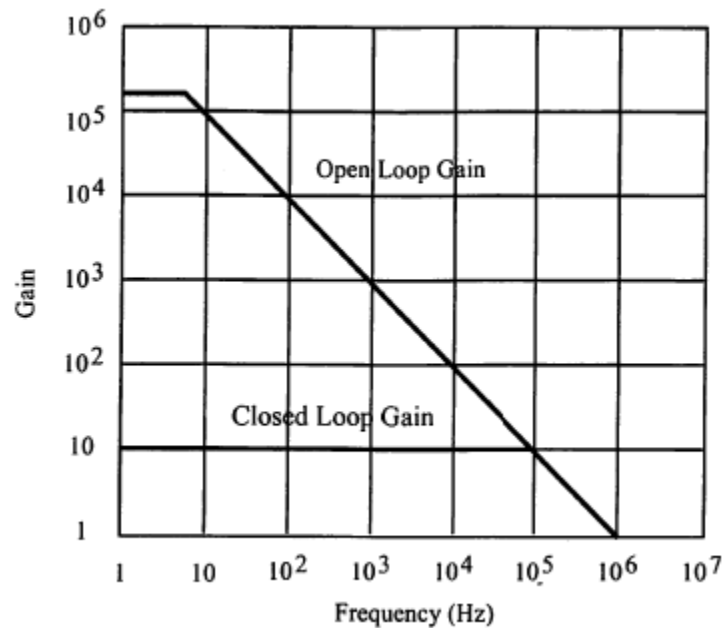

Figure 8.3 Typical Open Loop Gain vs. Bandwidth for 741 Op Amp



Figure 8.4 LM741 Pin-out diagram and schematic symbol.

Laboratory 8: OpAmps

Table 8.1 LM741 Specifications.

Electrical Characteristics⁽¹⁾

Parameter	Test Conditions	LM741A			LM741			LM741C			Units
		Min	Typ	Max	Min	Typ	Max	Min	Typ	Max	
Input Offset Voltage	$T_A = 25^\circ\text{C}$ $R_S \leq 10\text{ k}\Omega$ $R_S \leq 50\Omega$		0.8	3.0		1.0	5.0		2.0	6.0	mV
	$T_{AMIN} \leq T_A \leq T_{AMAX}$ $R_S \leq 50\Omega$ $R_S \leq 10\text{ k}\Omega$			4.0			6.0			7.5	mV
Average Input Offset Voltage Drift				15							$\mu\text{V}/^\circ\text{C}$

Table 8.2 LM741 Specifications cont.



LM741

www.ti.com

SNOSC25C – MAY 1998 – REVISED MARCH 2013

Electrical Characteristics⁽¹⁾ (continued)

Parameter	Test Conditions	LM741A			LM741			LM741C			Units
		Min	Typ	Max	Min	Typ	Max	Min	Typ	Max	
Input Offset Voltage Adjustment Range	$T_A = 25^\circ\text{C}$, $V_S = \pm 20\text{V}$	± 10				± 15			± 15		mV
Input Offset Current	$T_A = 25^\circ\text{C}$		3.0	30		20	200		20	200	nA
	$T_{AMIN} \leq T_A \leq T_{AMAX}$			70		85	500			300	
Average Input Offset Current Drift				0.5							nA/°C
Input Bias Current	$T_A = 25^\circ\text{C}$		30	80		80	500		80	500	nA
	$T_{AMIN} \leq T_A \leq T_{AMAX}$			0.210			1.5			0.8	μA
Input Resistance	$T_A = 25^\circ\text{C}$, $V_S = \pm 20\text{V}$	1.0	6.0		0.3	2.0		0.3	2.0		M Ω
	$T_{AMIN} \leq T_A \leq T_{AMAX}$, $V_S = \pm 20\text{V}$	0.5									
Input Voltage Range	$T_A = 25^\circ\text{C}$							± 12	± 13		V
	$T_{AMIN} \leq T_A \leq T_{AMAX}$				± 12	± 13					
Large Signal Voltage Gain	$T_A = 25^\circ\text{C}$, $R_L \geq 2\text{ k}\Omega$ $V_S = \pm 20\text{V}$, $V_O = \pm 15\text{V}$ $V_S = \pm 15\text{V}$, $V_O = \pm 10\text{V}$	50			50	200		20	200		V/mV
	$T_{AMIN} \leq T_A \leq T_{AMAX}$, $R_L \geq 2\text{ k}\Omega$, $V_S = \pm 20\text{V}$, $V_O = \pm 15\text{V}$ $V_S = \pm 15\text{V}$, $V_O = \pm 10\text{V}$	32			25			15			V/mV
	$V_S = \pm 5\text{V}$, $V_O = \pm 2\text{V}$	10									
Output Voltage Swing	$V_S = \pm 20\text{V}$ $R_L \geq 10\text{ k}\Omega$ $R_L \geq 2\text{ k}\Omega$	± 16 ± 15									V
	$V_S = \pm 15\text{V}$ $R_L \geq 10\text{ k}\Omega$ $R_L \geq 2\text{ k}\Omega$				± 12 ± 10	± 14 ± 13		± 12 ± 10	± 14 ± 13		V
Output Short Circuit Current	$T_A = 25^\circ\text{C}$	10	25	35		25			25		mA
	$T_{AMIN} \leq T_A \leq T_{AMAX}$	10		40							
Common-Mode Rejection Ratio	$T_{AMIN} \leq T_A \leq T_{AMAX}$ $R_S \leq 10\text{ k}\Omega$, $V_{CM} = \pm 12\text{V}$ $R_S \leq 50\Omega$, $V_{CM} = \pm 12\text{V}$		80	95		70	90		70	90	dB
Supply Voltage Rejection Ratio	$T_{AMIN} \leq T_A \leq T_{AMAX}$, $V_S = \pm 20\text{V}$ to $V_S = \pm 5\text{V}$ $R_S \leq 50\Omega$		86	96							dB
	$R_S \leq 10\text{ k}\Omega$				77	96		77	96		
Transient Response	$T_A = 25^\circ\text{C}$, Unity Gain	Rise Time		0.25	0.8		0.3			0.3	μs
		Overshoot		6.0	20		5			5	%
Bandwidth ⁽²⁾	$T_A = 25^\circ\text{C}$	0.437	1.5								MHz
Slew Rate	$T_A = 25^\circ\text{C}$, Unity Gain	0.3	0.7			0.5			0.5		V/ μs
Supply Current	$T_A = 25^\circ\text{C}$					1.7	2.8		1.7	2.8	mA
Power Consumption	$T_A = 25^\circ\text{C}$		80	150							mW
	$V_S = \pm 20\text{V}$ $V_S = \pm 15\text{V}$					50	85		50	85	

Laboratory 8 Procedure/Summary Sheet

Names _____

NOTE - An op amp always requires connection to an external power supply. Usually, two DC power supplies are required: +15V and -15V. In this lab you will get the two different voltage levels from your triple output power supply. When you build an op amp circuit, always check that a power source is connected to the op amp. Use a +/-15V supply for all circuits in this Lab.

1. Examine the usefulness of the high input impedance of the op amp by constructing the simple circuit known as the voltage follower. Begin by building the circuit shown in Fig. 8.5 consisting of a voltage divider (R_1 , R_2) and a load resistance (R_3)

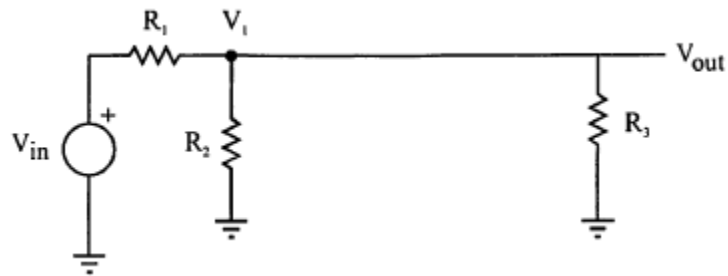

Figure 8.5 circuit without op-amp buffer.

where $R_1=R_2=R_3=10k\Omega$. Use $V_{in}=5V_{dc}$. Calculate the expected value for V_{out} , with and without the load resistance in the circuit.

Voltage	Calculated	measured
V_{out} (w/o R_3)		
V_{out} (with R_3)		

Now insert the op-amp buffer between the voltage divider and the load resistor as shown in Fig. 8.6. Be sure the op-amp has the proper power supply connections as well as the signal connections shown in the figure. Again calculate the expected value for V_{out} , with and without the load resistance in the circuit.

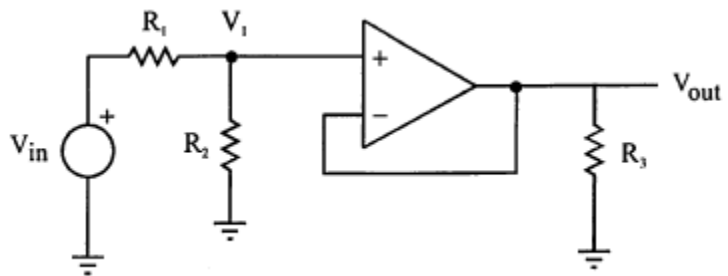

Figure 8.6 circuit with op-amp buffer.

Voltage	Calculated	measured
V_{out} (w/o R_3)		
V_{out} (with R_3)		

Explain to me the differences among the voltages measured in the two circuits.

Laboratory 8: OpAmps

You should be able to see now that the follower isolates the left part of the circuit from the right part. The follower effectively changes a high impedance output to a low impedance output. The result is that the output of the voltage divider is not changed by different load resistors.

2. Construct an inverting amplifier (see Fig. 5.7 in the textbook) with a gain of -10 and use it to determine the maximum output swing voltage in the following way. First, apply a $1 V_{pp}$ 1kHz sinusoidal signal. Then, increase the amplitude of the input slowly and note where the sinusoidal output is first distorted as you increase the input voltage. Be sure to use resistors in the $1 k\Omega$ to $100k\Omega$ range. What is the output voltage when you see the distortion? What is the cause of the distortion? Be sure to test your assertion.
3. Construct the modified integrator shown below. As a rule of thumb, you should select a shunt resistor (R_s) so that $R_s > 10 R_1$. Also, choose the product $R_1 C_1 \approx$ the period of the applied input voltage signal. Apply a 1 KHz, $1 V_{pp}$ square wave. Use the following component values: $C_1 = 0.1\mu F$, $R_s = 100k\Omega$, and $R_1 = R_2 = 10k\Omega$. Show that these selections are reasonable.

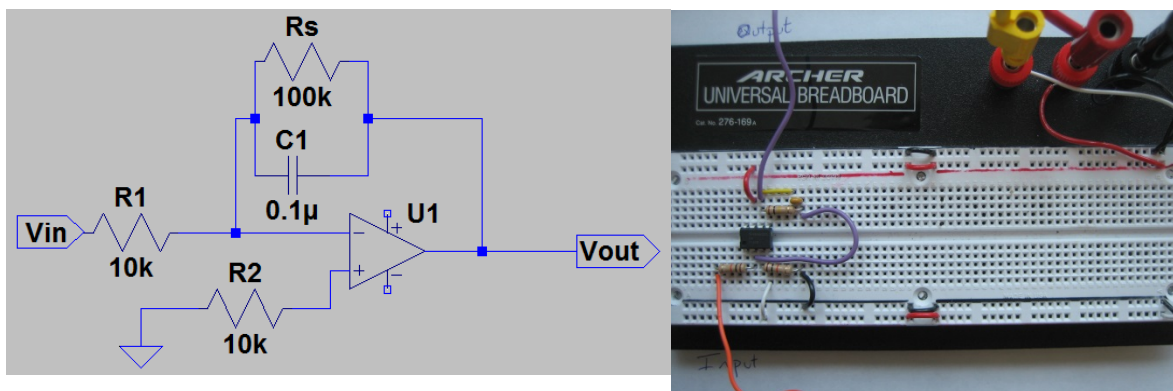

Figure 8.7 Integrator

Determine experimentally the frequency range over which the circuit functions as an integrator. To do this systematically, adjust the input signal to be a $1 V_{pp}$ square-wave with no DC offset. As you vary the frequency over a wide range you will notice that the output will deviate from the expected triangular wave (integrated square wave). Determine and report the approximate

Laboratory 8: OpAmps

frequency below which the circuit does not operate as an integrator (i.e., the output is not a sharp triangular wave).

- Construct the difference amplifier shown below with a gain of 1 using $R_1 = R_F = 10\text{k}\Omega$. Use 15 Vdc for V_1 and 5Vdc for V_2 . Explain what you would expect at the output V_{out} and note any discrepancies in your measurement.

Now attach a 1 V_{pp} 1kHz sine wave to both inputs, and again explain what you would expect and note any discrepancies with the measured signal.

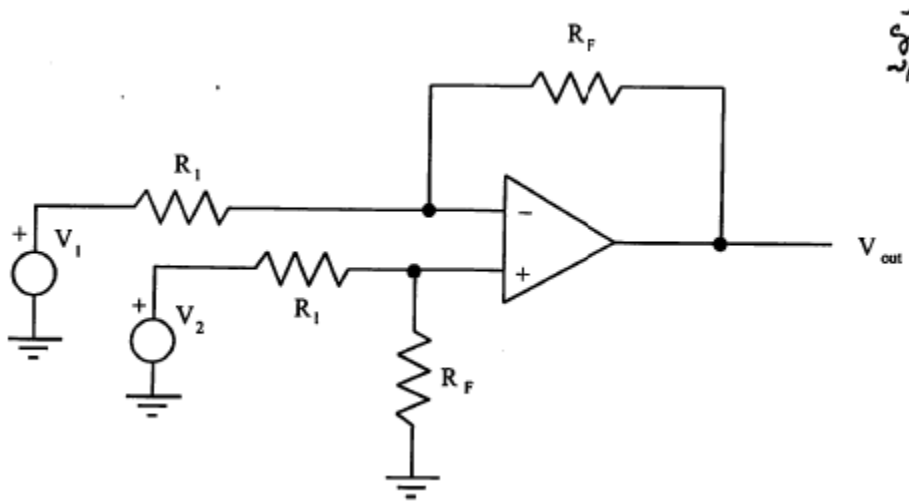

Figure 8.8 Difference Amplifier

Lab 8 Questions

Names _____

1. Find the specifications for the 741C op amp online. Record the values for each of the characteristic parameters listed below. Also, discuss the significance of each parameter.
 - Input Impedence
 - Output Impedence
 - Maximum Gain
 - Output Voltage Swing
 - Short Circuit Output Current
2. Explain how the voltage buffer "isolates" the input from the output, and explain why this might be useful.
3. What is the fall-off frequency (approximate bandwidth) of a 741 op amp circuit designed with a closed loop gain of 100?
4. The output of the difference amp was not exactly zero when the inputs are of equal magnitudes. Suggest possible causes for this discrepancy.

Extra Credit (10%):

While the difference amplifier in Fig. 8.9 is functional, the instrumental amplifier is more robust and is a workhorse. It is simpler to build it from a chip that has multiple op-amps (all using the same power source) such as the LM224.

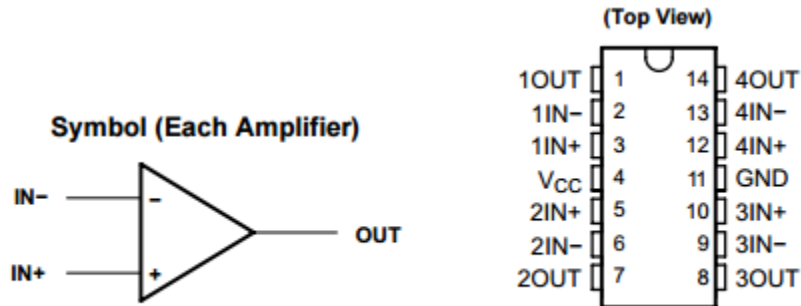

Figure 8.9 The LM224 is a general purpose chip with four independent op amps inside.

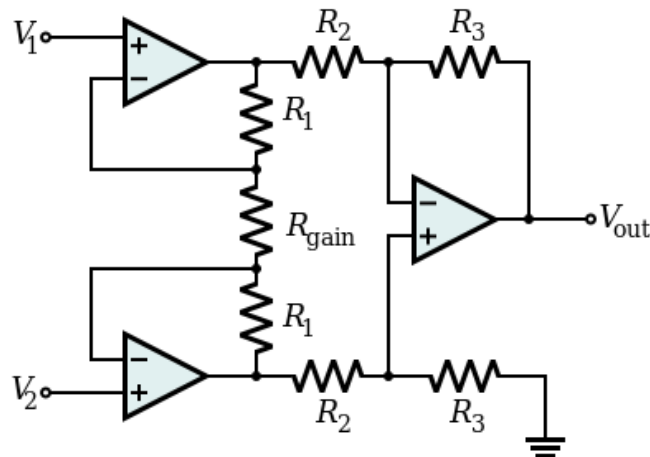

Figure 8.9: An instrumental amplifier.

The output of an instrumental amplifier is

$$V_{out} = \left(1 + \frac{2R_1}{R_{gain}}\right) \frac{R_3}{R_2} (V_2 - V_1)$$

And it is common to select $R_2=R_1$ and $R_3=2 R_1$. Predict the behavior of, build and then test the circuit in Fig. 8.11 using $R_1=1k\Omega$ and $R_{gain} = 5k\Omega$ with the following input.

Input	Predicted output	Observed output
$V_1=1V_{DC}$ and $V_2 =0.5V \sin(2\pi \text{ 1kHz } t)$		

*Note: you must show me your working circuit to get credit.

Laboratory 8: OpAmps

Replace R_{gain} with a 5-10k Ω potentiometer (pot). Some pots have 2 leads and some have 3, some have a linear scale and some are logarithmic (for audio applications). Experiment with your pot so you know how it works.

$R_{gain} =$ _____ (max value and scale type)

	Predicted output	Observed output
R_{gain} at max resistance		
R_{gain} at 20% of max resistance		
R_{gain} near min resistance		

Extra Credit (10%)

One of the limitations of an op-amp is the current the op-amp can provide. The circuit in Figure 8.11 uses 2 BJTs, one an npn (TIP31) the other a pnp (TIP32) to drive a large current load.

Build this circuit and drive it with your music (at signal). Let me hear it for credit.

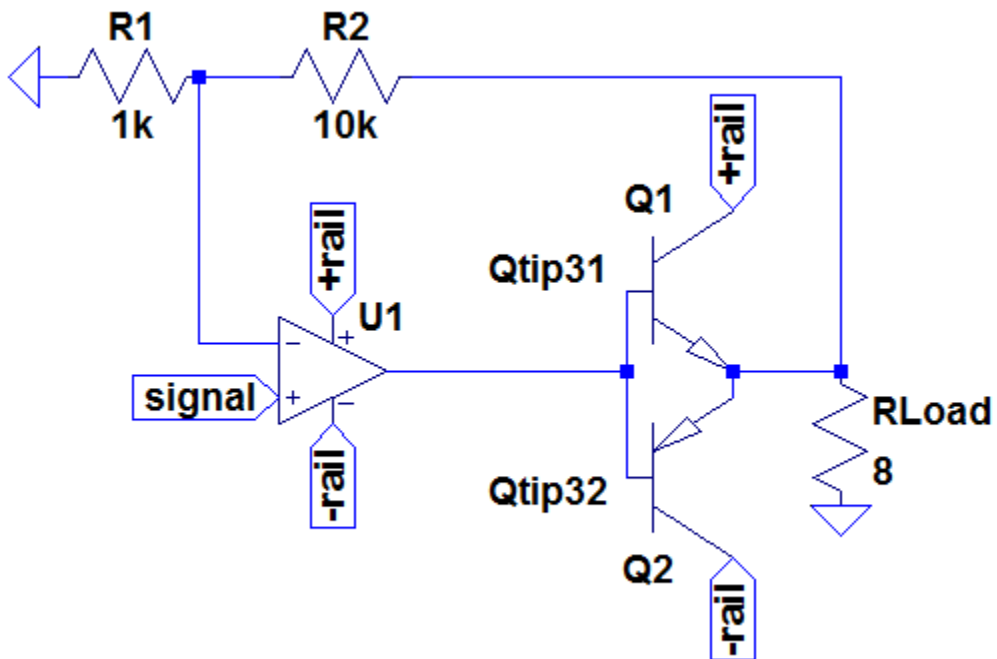

Figure 8.11 A non-inverting amplifier with a pair of transistors between the output of the op-amp and the large speaker (depicted as the 8 Ω resistor RLoad).