

# EXPERIMENT 5 : *THE DIODE*

## Component List

- Resistors, one of each
  - 1 330 $\Omega$
  - 1 1k $\Omega$
  - 1 10k $\Omega$
- 4 1N4004 ( $I_{\max} = 1\text{A}$ ,  $\text{PIV} = 400\text{V}$ ) Diodes
- Center tap transformer (35.6V<sub>pp</sub>, 12.6 V<sub>RMS</sub>)
- 100  $\mu\text{F}$  Electrolytic Capacitor

## Introduction

Until now, we have focused on passive elements, i.e., elements through which current is linearly proportional to voltage. We will now begin our study of non-linear devices with the diode.

The ideal diode has the following characteristics:

- In the forward bias direction, the diode acts as a short circuit, passing as much current as the circuit will provide with no voltage drop across the diode.
- In the reverse bias direction, the diode acts like an open circuit, passing no current for any amount of reverse bias.

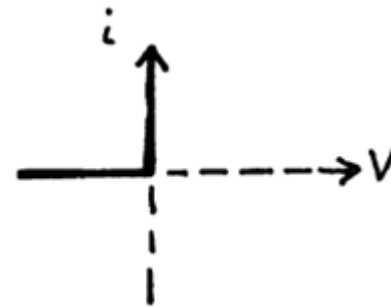

Figure 5.1 Ideal diode

Figure 1 is a typical plot of an ideal device showing current versus voltage in both forward and reverse biased directions. Real diodes only approximate this behavior and look more like Fig. 2.

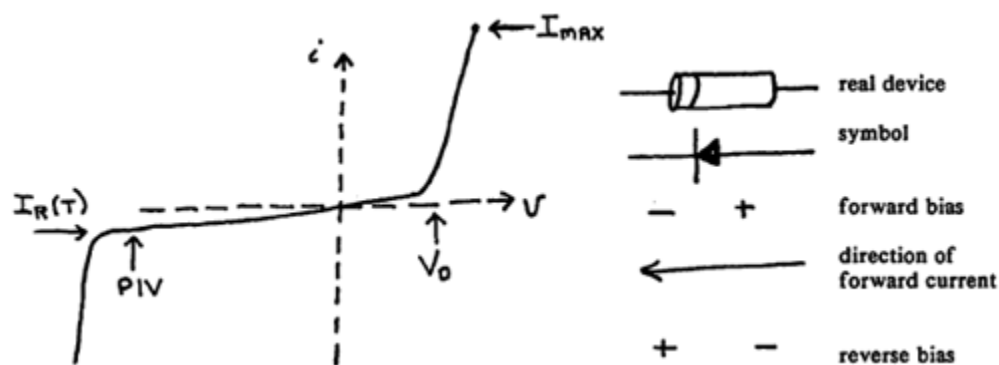

Figure 5.2 Semiconductor PN junction diode characteristic and symbol

We are interested in the solid state PN junction diode which has the following type of characteristics. The diode's symbol is an arrow with a bar, the arrow indicates the direction in which positive forward current flows. Figure 2 shows the positive forward bias needed to make the diode conduct,  $V_D$ , and the peak inverse voltage rating of the diode, PIV, beyond which the diode also conducts. Note that exceeding PIV is destructive (non-reversible breakdown) to many diodes. The small reverse current,  $I_R(T)$  is typically 10 pA for a silicon diode at room temperature and rapidly increases with increasing temperature. For example, at high temperatures ( $\sim 200^\circ\text{C}$ ) the junction no longer acts like a diode and passes in both directions. The diode's temperatures will rise as current flows through the diode. Excessive temperature rise can be controlled either by limiting the power the device dissipates for current in the forward direction or by employing a heat sink. The first approach implies a maximum current,  $I_{\text{max}}$ , for the diode in the forward direction.

The real diode we will use is a 1N4004 (400 V PIV,  $I_{\text{max}} = 1 \text{ A}$ ) and the white line at one end indicates the direction in which positive forward current flows.

### Part I: Diode Characteristics

1. Set up the following circuit with the voltmeter, on the 4 VDC scale. Use the protoboard to mount the diode. The  $330\Omega$  resistor limits the current, regardless of what the diode does.
2. Slowly increase the power supply voltage from zero. Record on the data sheet representative values of voltage versus current. Do not exceed 100 mA.
3. Power down.
4. Graph  $I$  vs  $V$  and estimate  $V_D$ .

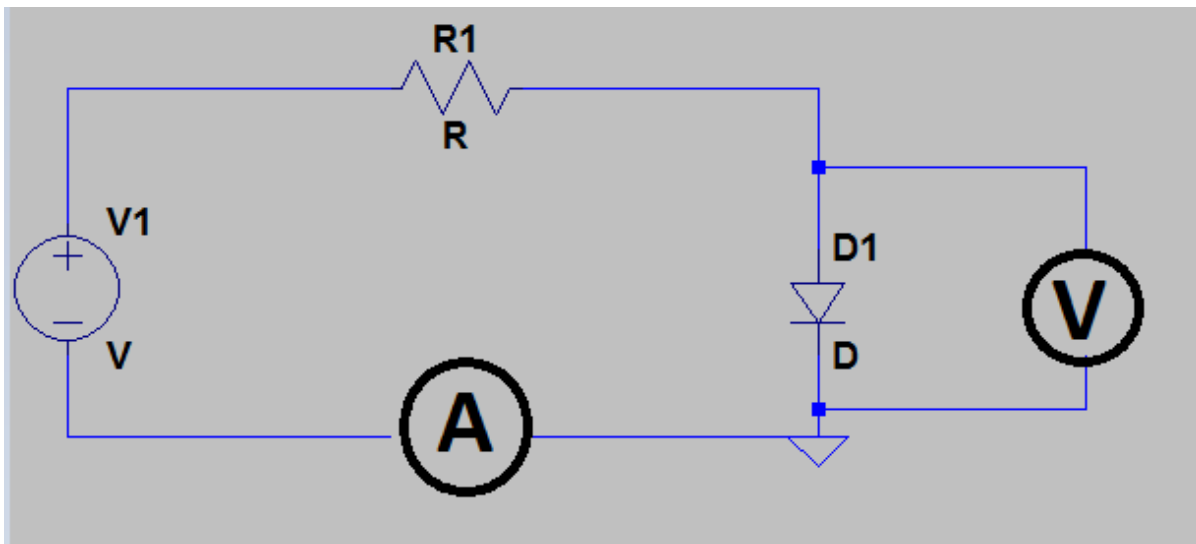

Figure 5.3 Diode Characteristic Circuit

## Part II: Half Wave Rectifier

Power generators usually produce AC voltages since they are most convenient for power transmission. On the other hand many devices require DC voltages. Rectifiers produce DC from AC (which usually has no DC component) by redirecting the AC current flow in such a way as to produce a DC component, then to filter out the remaining AC component. The diode in Figure 5.4 is a rectifier as you will verify.

1. Construct the following circuit. Switch your oscilloscope to DC coupling.

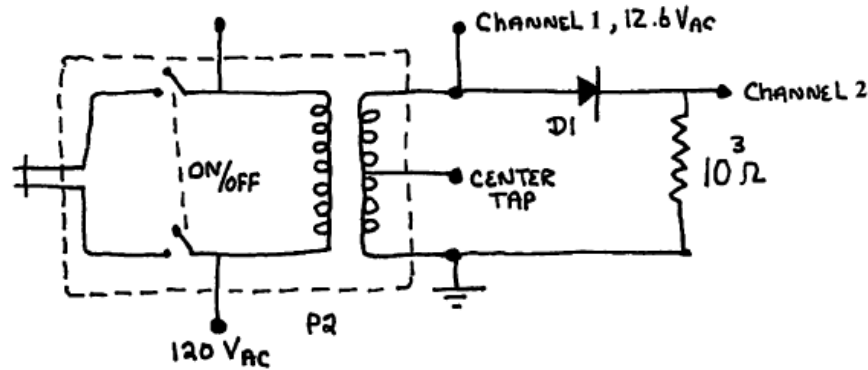

Figure 5.4 Center Tap Half Wave Rectifier

The transformer converts 60 Hz 120 V RMS line voltage in the primary to 12.6 V RMS across the secondary. The secondary has a center tap which can split the secondary into two 6.3 V RMS parts. The secondary is isolated from the primary. By grounding the bottom of the secondary (see Fig. 5.4), point 1 will be positive during a half cycle, then negative in the following half cycle.

2. Use your scope to observe the voltage at point 1.
3. Now observe the voltage across the resistor at point 2. Make sure that the scope is DC coupled. (See what happens when the scope is AC coupled.) Draw the waveform at the 2 output.
4. This is an example of a half wave rectifier. Reverse the direction of the diode and draw the waveform at the 2 output.

Both configurations are called half-wave rectifiers; i.e., for one polarity the diode conducts and the input signal appears across the resistor, while for the opposite polarity the diode does not conduct and the input appears across the diode.

This half-wave rectified signal can be filtered to produce a DC voltage but as a practical matter it seems we are wasting half of the generating capacity of the transformer by not utilizing the other half of the generator signal.

### Part III: Full Wave Rectifier

1. Construct the following circuit using the center tap of the secondary. DC couple your oscilloscope.
2. Draw the resultant waveform across the resistor.

This is an example of a full-wave rectifier. When the top loop is forward biased, the  $D_1$  diode conducts. When the bottom loop is forward biased, the  $D_2$  diode conducts. In either case, the forward current from the diode passes through the resistor in the same direction; thus, both half cycles now have the same polarity. Note also that the rectified voltage across the resistor is the center tap peak voltage which is equal to one-half the peak secondary voltage.

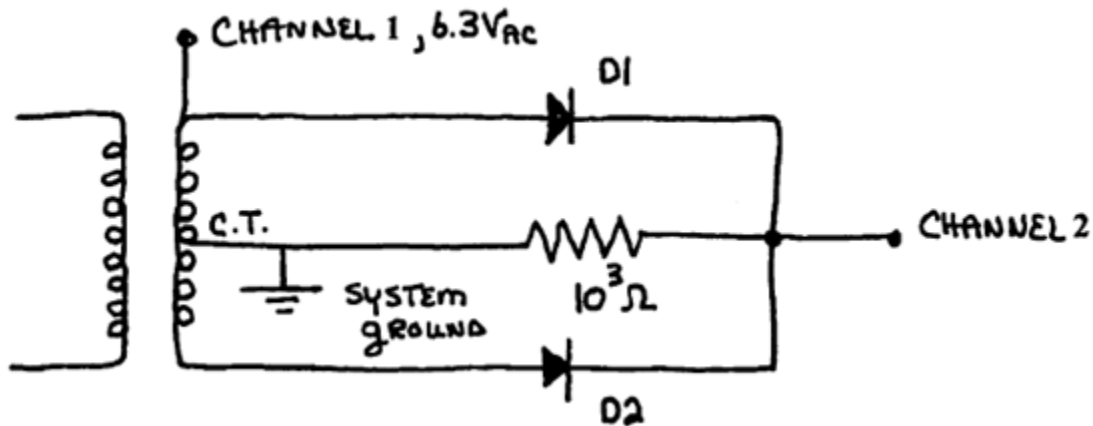

Figure 5.5 Center tap full wave bridge rectifier

3. We can rectify the full secondary voltage with a bridge rectifier. Construct the following circuit.

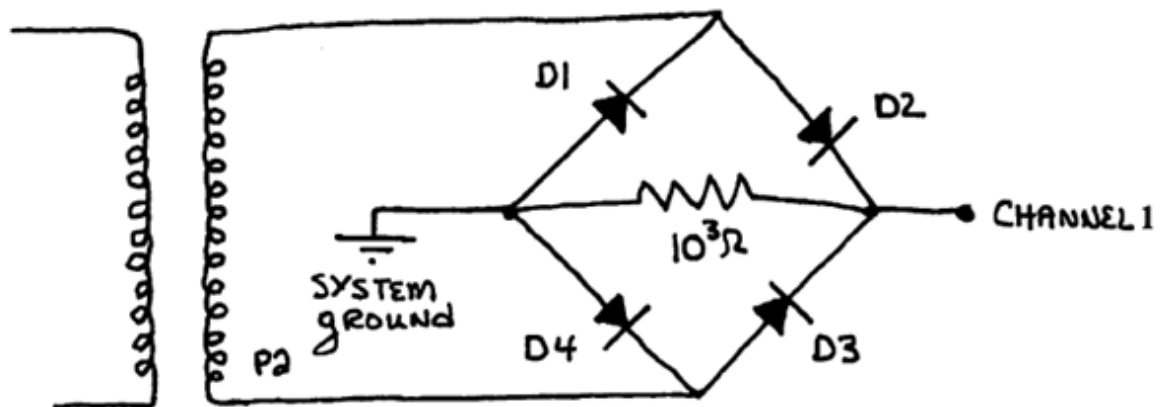

Figure 5.6 Full-wave bridge rectifier

Note from the figure that opposite pairs of diodes steer the current through the resistor during alternate half cycles, ( $D_1, D_3$ ) then ( $D_2, D_4$ ). Further, they steer the current in only one direction through the resistor depending on the polarity of the secondary. Finally, the rectified voltage is the full voltage of the secondary.

You might ask yourself why you don't use the second scope input to observe the secondary voltage with this configuration. Can you guess what you would see? Take a look at the center tap with the B input. The problem is the position of the ground, which must be placed where it is to look across the resistor.

4. Leave this setup as is for the moment

#### IV. The RC Filter

Now that we have a rectified signal, we would like to convert it into a DC signal with as little AC ripple as possible. A simple technique for low current cases is the capacitance filter. Consider the effect of placing a  $100\ \mu\text{F}$  capacitor across the load resistor, initially uncharged.

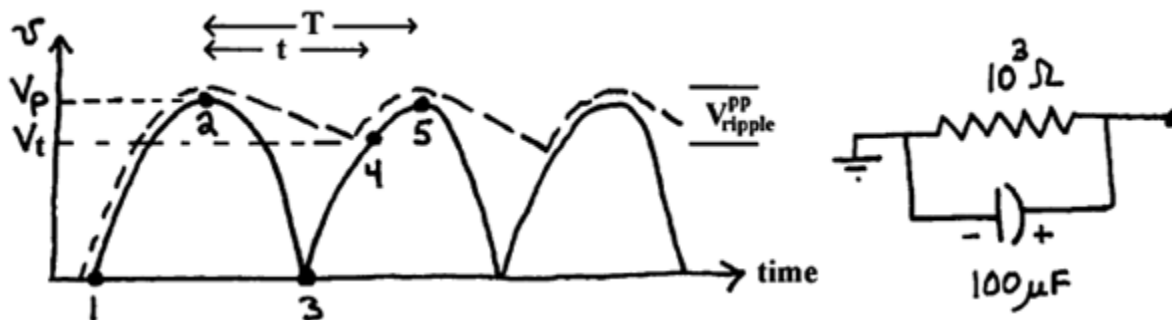

Figure 5.7 Effect of an RC filter on a full wave rectifier

On the very first half cycle as the secondary voltage rises from point 1 to 2 (solid line), diodes  $D_2$  and  $D_4$  are forward biased and conduct, current flows through the resistor, and the capacitor is charged up to  $V_p$ . As the secondary voltage falls towards point 3, the capacitor cannot discharge its positive charge through diode  $D_2$  or  $D_4$ , since they are reverse biased; thus, the voltage at point A does not follow the secondary. (A similar argument follows for the negative charge and diodes  $D_1$  and  $D_3$ .) However, the capacitor can discharge through

$$v(t) = v_p e^{-t/\tau} \tag{1}$$

where the time constant in this case is  $\tau = RC = 1k\Omega \cdot 100\mu\text{F} = 100\text{ms}$ . At the same time, the period of the full wave rectified signal is half that of line voltage,  $T = \frac{1}{2f} = \frac{1}{120\text{Hz}} = 8.5\ \text{ms}$ . Thus, the RC time constant is much longer than the period of the full wave rectified signal, i.e.  $T \ll \tau$ . Since  $t \sim T$ , we can make the approximation that

$$v(t) \cong v_p \left(1 - \frac{t}{\tau}\right) \quad \text{or} \quad V_T \cong v_p \left(1 - \frac{t}{\tau}\right) \tag{2}$$

over a half cycle. The capacitor discharges linearly until the secondary voltage reverses itself and climbs to point 4 at which point diodes  $D_1$  and  $D_3$  conduct and recharge the capacitor back up to  $V_p$  at point 5. Then the whole process repeats itself (dotted line).

The AC peak-to-peak ripple voltage is just

$$V_{ripple}^{pp} = V_p - V_T = \frac{V_p T}{\tau} \quad (3)$$

The effective DC voltage is roughly  $V_p$  less half the peak-to-peak AC ripple magnitude, i.e.,

$$\begin{aligned} V_{ripple}^p &= \frac{V_{ripple}^{pp}}{2} = \frac{V_p T}{2\tau} \\ V_{DC} &\cong V_p \left(1 - \frac{T}{2\tau}\right) \cong V_p \end{aligned} \quad (4)$$

The AC ripple voltage riding on  $V_{DC}$  is roughly triangular and the RMS value for a triangular waveform is  $V_R/\sqrt{3}$ . The effectiveness of the filter is given by the ripple factor

$$r = \frac{V_r^{RMS}}{V_{DC}} \cong \frac{T}{2\sqrt{3}\tau} \quad (5)$$

1. Determine the ripple factor experimentally and theoretically for  $R=1k\Omega$  and  $10k\Omega$ . When you connect the  $100\mu F$  capacitor to the full wave bridge, be sure to observe the proper polarity. To measure the AC ripple riding on a large DC background, switch to AC coupling on your oscilloscope. With the DC component blocked you can increase the gain of the oscilloscope to measure the peak-to-peak ripple voltage.

NAMES \_\_\_\_\_

**PART I:**

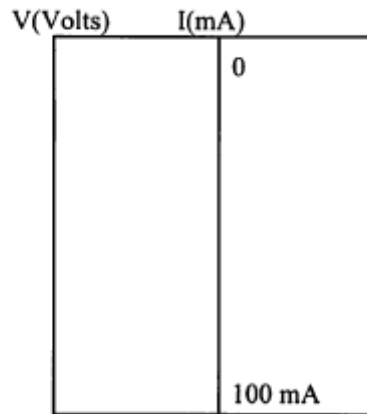

$V_D \cong$

**PART II:**

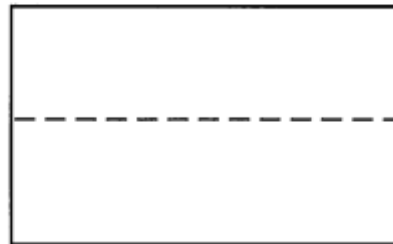
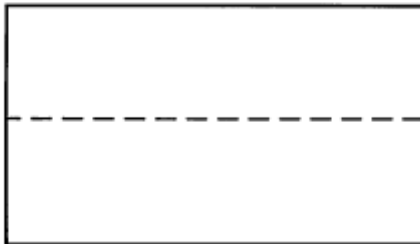

**PART III:**

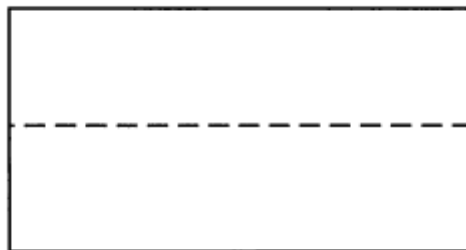

**PART IV:**

	$R_L = 10^3 \Omega$	$R_L = 10^4 \Omega$
$V_{DC}$		
$V_{ripple}^{pp}$		
$\Gamma^{exp}$		

	$R_L = 10^3 \Omega$	$R_L = 10^4 \Omega$
$\Gamma^{theory}$		

Note that the DC voltage and the ripple factor depend on the load. How they change with load is a measure of the regulation of the power supply. We will find later that there are ways of improving the regulation of DC power supplies.