

Experiment 4:

Coefficient of Performance¹

Introduction

Some heat pumps, such as refrigerators and air conditioners, are used for their cooling effect. They pump heat out of a container or a building, making the interior cooler than the surrounding environment. But a heat pump can also be used to pump heat into a building, making the interior warmer than the surrounding environment.

An important property of a heat pump is how much energy it uses to move a certain amount of heat. In this activity you will measure the Coefficient of Performance of a heat pump working in both modes, and discover how a heat pump can be more efficient at heating a building than conventional methods.

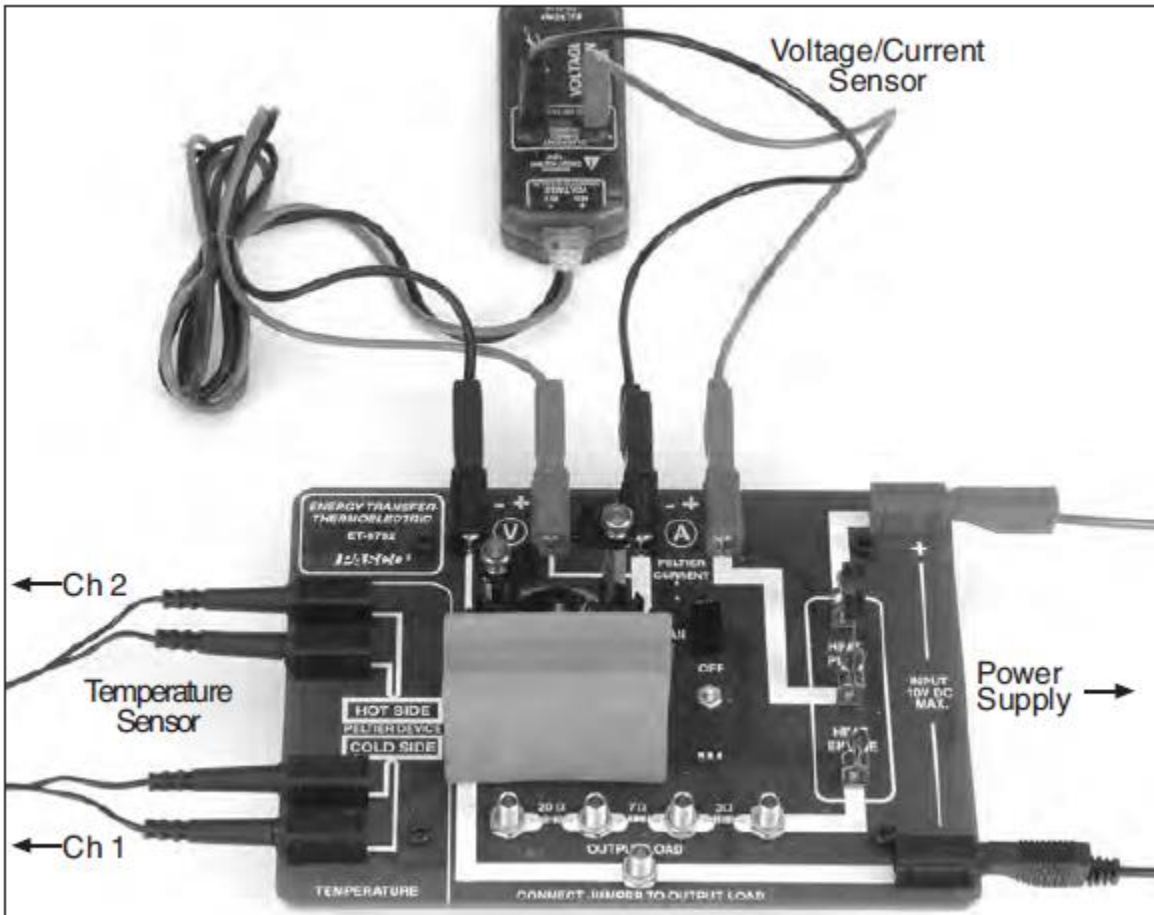

¹ Adapted from the Pasco instructions included with the apparatus.

Set-Up

1. Input Power: Set the Heat Pump/Heat Engine switch to the neutral position (straight up). Connect the power supply using banana patch cords to the input power terminals on the circuit board as shown in picture. Note the polarity.
2. Heat Sink and Insulator: Attach the heat sink to the aluminum block on the Hot Side of the Peltier. Place a foam insulator on the other block.
3. Temperature: Connect the cables from the temperature ports on the circuit board to the Quad Temperature Sensor. Connect the Cold Side to Channel 1 of the sensor and the Hot Side to Channel 2.
4. Voltage: Connect the voltage leads of the Voltage/Current Sensor to the Voltage Ports on the board. Note the polarity.
5. Current: Connect separate red and black banana patch cords from the current input of the Voltage/Current sensor to the Current Ports on the board. Note the polarity.
6. Use Capstone to display the input power and temperature of the aluminum blocks.

Background

You will measure and record the temperature of both aluminum blocks, and the voltage and current applied to the Peltier. From these measured quantities, you will calculate the heat flow, power and work.

Heat vs. Temperature

The relationship between heat flow and temperature change is given by

$$Q = mc\Delta T$$

where:

Q = heat transferred,

m = mass of the aluminum block,

c = specific heat of aluminum = 0.90 J/(g·°C),

ΔT = change in temperature.

Use a positive value of Q_{hot} to represent heat flowing into the hot block, and a positive value of Q_{cold} to represent heat transferred out of the cold block.

The temperature of each block is measured by the embedded thermistor. The mass of each block is about 19 g. For greater precision you should measure the block's volume with calipers and use the density of aluminum, 2.7 g/cm³, to calculate the mass.

Input Power and Work Done by the Peltier

Input Power from the power supply equals the rate at which the Peltier does work to pump heat out of the cold reservoir and into the hot reservoir. The Voltage/Current Sensor measures the voltage applied to the Peltier, and the current that flows through it. Power = Voltage × Current.

The area under the plot of Input Power versus time equals the energy supplied to the Peltier, which equals the work, W , done by the Peltier.

Useful data

Be sure that you only include data after the temperature of the two plates cross each other.

Procedure

Refrigerator

Before you start, the knife switch should be in the neutral position (straight up) and the fan should be switched off. Make sure that the foam insulator is on the cold block, and that the heat sink is on the hot block.

Set the DC Voltage to about 5 volts.

Click the Start button.

Observe the temperatures of the hot and cold blocks; they should be within 0.1 °C of each other. (If they are not, turn on the fan and wait until the temperatures have equalized. Then turn the fan off and proceed.)

Set the knife switch to Heat Pump mode. Allow the heat pump to run for 10 to 15 seconds, then open the switch. Watch the temperature graphs; once the temperatures have peaked out, stop data recording. You need to give the blocks a few seconds to reach a maximum or minimum before you stop recording.

Heat pumps are rated by the Coefficient of Performance, k . In the case of a heat pump used for cooling (such as a refrigerator) the Coefficient of Performance is

$$k = \frac{Q_{cold}}{W}$$

The Coefficient of Performance expresses how much heat the heat pump removes from the cold side compared to how much energy it uses to move the heat.

1. Use your values for the heat pumped out of the cold block (Q_{cold}) and the area under the Power versus time curve (W) to calculate the Coefficient of Performance, k , for your model refrigerator.
2. For real heat pumps k is usually expected to be greater than 1. Is this the case for your model?
3. Your heat pump can also be thought of as a model air conditioner, a device used to keep the inside of a building cooler than the outside air. In terms of moving heat, what does an air conditioner do to keep a building cool? (Keep in mind that an air conditioner does not necessarily move air into or out of the building.)
4. Compare your model to a building being cooled by an air conditioner. What does the Peltier represent? What does the cold block represent? What does the hot block represent?
5. If you were selecting an air conditioner to keep your home cool, would you choose one with a high or low coefficient of performance? Explain why.

Reversible Heat Pump

A certain kind of air conditioner, known as a reversible heat pump, can also be used to heat a building. You will now use the peltier to model a reversible heat pump being used to keep a building warmer than the surrounding air.

Place the heat sink on the cold block, and the foam insulator on the hot block.

Delete the data that you have previously recorded. (Click on the Experiment menu and select Delete All Data Runs.)

Click the Start button. Make sure that the hot and cold blocks are within 0.1 °C of each other before proceeding. (If they are not, remove the insulator, turn on the fan and wait for the temperatures to equalize. Then turn off the fan, replace the insulator and proceed.)

Set the switch to Heat Pump mode. Allow the heat pump to run for 10 to 15 seconds, then open the switch. Watch the temperature graphs; once the temperatures have peaked out, stop data recording.

For a reversible heat pump heating a building, we are interested in the heat pumped into the building, Q_{hot} . (This is opposed to the previous case where we were interested in the heat pumped out of the building.) Thus the Coefficient of Performance is

$$k = \frac{Q_{hot}}{W}$$

Use your values for the heat delivered to the hot block (Q_{hot}) and the area under the Power versus time curve (W) to calculate the Coefficient of Performance, k .

6. If you had used a simple resistor (rather than the peltier) to heat the aluminum block, and used the same amount of energy (W), what would have been the maximum amount of heat transferred to the block?
7. Compare your model to a building being heated by a reversible heat pump. What does the Peltier represent? What does the cold block represent? What does the hot block represent?
8. Why is it important for k to be greater than 1 for a reversible heat pump? Compare this to a simple electrical heater. How much heat is delivered to a building using a simple heater supplied with 100 J of electrical energy? How much heat is delivered to a building using a heat pump, with $k = 2$, that uses 100 J of electrical energy to pump heat from outside to inside the building?

Further Investigation

Think of a factor that you can vary in the experimental set-up. Predict how varying that factor would affect the coefficient of performance in heating or cooling mode. Do an experiment to test your prediction.