

# 1 Experiment 2:

Load resistance and efficiency

## Introduction

In this experiment you will examine the relationship between output load resistance and the power generated by the Peltier when it is operating in heat engine mode.

You will observe the output power as you vary the load resistance while keeping everything else constant (the temperature difference between the blocks, for instance). Since it is not possible to hold the blocks at a steady temperature difference, you will take the Peltier through several identical cycles of heating and cooling, and measure the power each time a certain temperature difference occurs. You will repeat the cycle for each value of load resistance that you test, ranging from slightly over  $0\Omega$  to  $30\Omega$ .

Before you start, predict what you will discover about the relationship between output power and load resistance. Record your prediction using words, numbers and a graph. Explain your reasoning.

## Set-Up

Input Power: Set the Heat Pump/Heat Engine switch to the neutral position (straight up). Connect the power supply, voltage, current and temperature probes to the apparatus, See Fig. 1

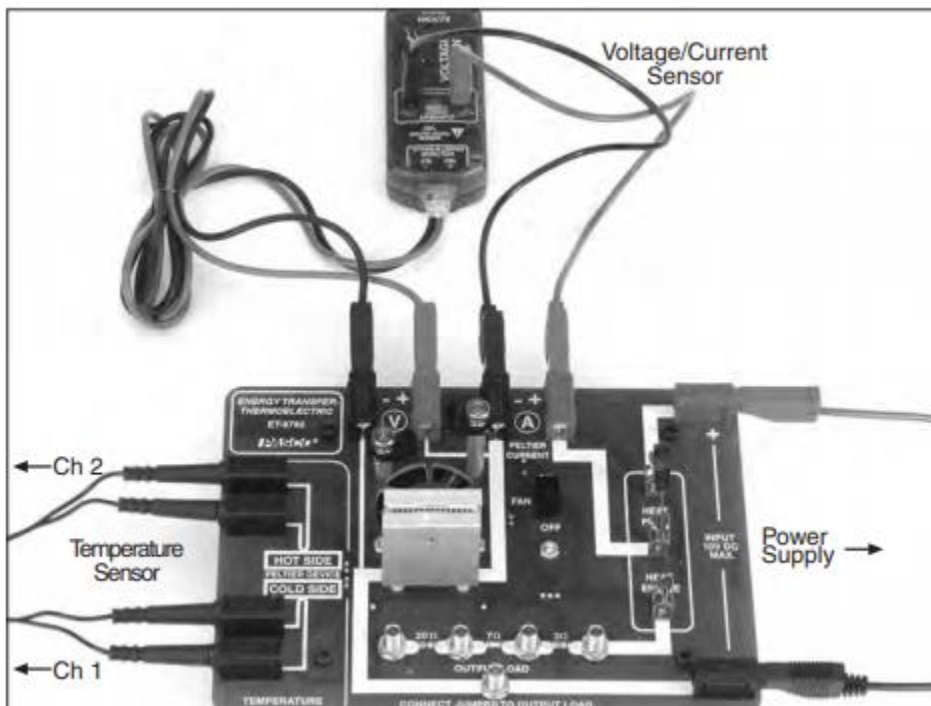

Figure 1 Peltier apparatus with power and probes connected.

Start Capstone and configure it to display power generated vs  $\Delta T = T_{\text{hot}} - T_{\text{cold}}$ .

You will cause a  $\Delta T$  greater than  $35^\circ\text{C}$  using the heat pump and then record the voltage, current, and temperatures with the apparatus in heat-engine mode

<sup>1</sup> An adaptation of the lab instructions provided by Pasco with their equipment.

until  $\Delta T = 5^\circ\text{C}$ . You will do this for loads of 0, 3, 7, 10, 20, and  $30\Omega$ s.

### Tips:

- Use 6V on the power supply to cause the  $\Delta T$ .
- Achieve a large  $\Delta T$  more quickly by using the heat sink and fan on the hot block.
- Insulate both blocks after you shut off the heat pump and before you start the heat engine.

## Analysis

From the data that has been recorded you will extract the data needed to plot a graph of Power Generated ( $P$ ) versus Load Resistance ( $R_L$ ) at  $\Delta T = 30^\circ\text{C}$ .

On the graph of  $P$  vs.  $\Delta T$  use the smart cursor to read the power generated at  $\Delta T = 30^\circ\text{C}$  for each value of load resistance. (Use the zoom select tool to change the scale of the graph and enlarge the area around the data at  $30^\circ\text{C}$  in order to read the data precisely.)

Enter the values in the Power vs. Load table. As you enter data into the table, they will be plotted on the Power vs. Load Resistance graph.

1. At what value of  $R_L$  is the maximum power generated?
2. For output loads less than and greater than the optimal value, why does the peltier generate less power?

All real electrical power supplies (including the peltier heat engine) have an internal resistance,  $R_i$ . They can be modeled as an ideal voltage source in series with a resistor, as shown below (with an output load connected).

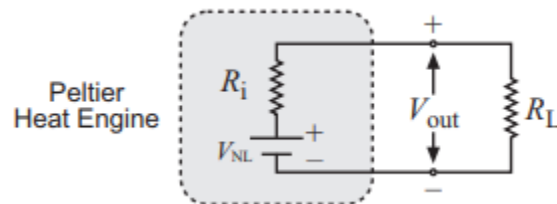

The voltage of the ideal voltage source,  $V_{NL}$ , is called the no-load voltage. For a Peltier heat engine  $V_{NL}$  depends only on  $\Delta T$ .

3. Under what condition does the output voltage ( $V_{out}$ ) equal  $V_{NL}$ ?
4. How would you directly measure  $V_{NL}$  at  $\Delta T = 30^\circ\text{C}$ ?
5. Write a theoretical equation for output power,  $P$ , in terms of  $V_{NL}$ ,  $R_i$  and  $R_L$ . Make a graph of  $P$  vs.  $R_L$  (choose some arbitrary values for  $V_{NL}$  and  $R_i$ ). Based on your equation and graphs, under what condition is  $P$  at its maximum?
6. In this experiment, one of the data points was taken with  $R_L = 0$ . According to your equation, what is the theoretical power generated when  $R_L = 0$ ? Was this the case in your experiment? There is another source of resistance that we haven't considered yet, which is the resistance of

the traces, leads and sensors in the circuit. Let's call it  $R_T$ . If we add in  $R_T$ , the circuit can be modeled thus:

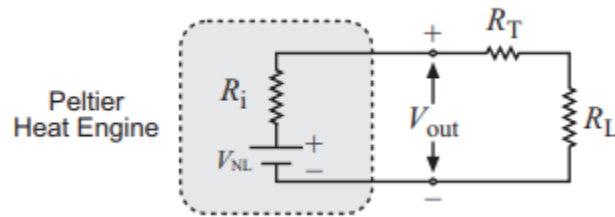

7. Rewrite the theoretical equation for  $P$  taking  $R_T$  into account.
8. Fit this equation to your experimental data. What is the no-load voltage at  $\Delta T = 30^\circ \text{C}$ ? What is the internal resistance of the Peltier? What is  $R_T$ ?

#### Further Investigation

1. Make a direct measurement of the no-load voltage at  $\Delta T = 30^\circ \text{C}$ .
2. Make a direct measurement of  $R_T$  (or measure as much of it as possible).
3. Predict how your results would differ if you repeated your analysis for a different value of  $\Delta T$ ? Test your prediction.
4. For your graph of Power vs. Load Resistance, what did you do to ensure that only  $R_L$  and  $P$  varied, and that all other experimental parameters stayed constant? Evaluate how successful these measures were. Discuss how you could improve them.
5. In the analysis we assumed that  $V_{out}$  was constant for all values of  $\Delta T = 30^\circ \text{C}$ . Do an experiment to test that assumption.
6. For any given output load, quantitatively describe the relationship between  $P$  and  $\Delta T$ .