

EXPERIMENT 8: LRC CIRCUITS

Equipment List

- S_1 BK Precision 4011 or 4011A 5 MHz Function Generator
- OS BK 2120B Dual Channel Oscilloscope
- V_1 BK 388B Multimeter
- L_1 Leeds & Northrup #1532 100 mH Inductor
- R_1 Leeds & Northrup #4754 Decade Resistor
- C_3 Cornell-Dubilier #CDA2 Decade Capacitor
- C_2 Cornell-Dubilier #CDB3 Decade Capacitor
- General Radio #1650-A Impedance Bridge

Introduction

Consider the LRC circuit drawn to the right. According to Kirchoff's Law, at any time after the switch is closed we must find

$$\begin{aligned} V &= V_R + V_C + V_L \\ V &= iR_t + \frac{Q}{C} + L \frac{di}{dt} \end{aligned} \quad (1)$$

where the total resistance in the circuit is the sum of the external resistance and the internal resistance of the inductance; i.e. $R_t = R + R_L$. Taking account of the relation $dq/dt = i$, after the switch is closed, the derivative of this equation is

$$\frac{dV}{dt} = R_t \frac{di}{dt} + \frac{1}{C} i + L \frac{d^2i}{dt^2} \quad (2)$$

A solution to this second order differential equation is known to be damped harmonic and, for the initial conditions $q = i = 0$, given by

$$i = \frac{V}{L\sqrt{\delta}} e^{-\frac{R_t}{2L}t} \sin[(\sqrt{\delta})t] \quad (3)$$

This equation contains an exponential damping term times a sine wave term where the frequency of the sine wave is

$$\omega = \sqrt{\delta} \quad \delta = \frac{1}{LC} - \frac{R_t^2}{4L^2} \quad (4)$$

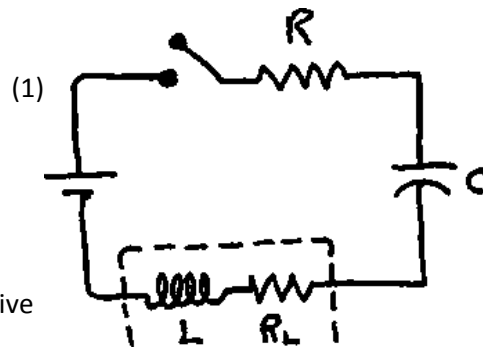

Figure 1: LRC Circuit

Experiment 8, RLC Resonant Circuits

This solution has three regions of interest:

1. **underdamped** ($\delta > 0$) - the solution is damped oscillations. $i \rightarrow 0A$ crossing the line $i=0A$.
2. **overdamped** ($\delta < 0$) - the argument of the sine function is complex; thus, the sine function becomes a real exponential. $i \rightarrow 0A$ without crossing $i=0A$.
3. **critically damped** ($\delta = 0$) - the current $i \rightarrow 0A$ in the shortest possible time without crossing $i=0A$.

It should be recognized that in any circuit which undergoes an abrupt change in voltage these effects will be present. Case one is the most frequent and is called ringing.

In an alternating current LRC circuit the change in voltage with time in equation 2 is no longer zero, and whatever transient effects due to the turning on of the AC generator will quickly disappear. For a sine wave input, the solution to equation 2 is also a sine wave. For the series circuit, the current is the same through all components. As we observed last week, the voltage across the capacitor lags the current by 90° . Thus, V_L and V_C are 180° out of phase with one another in the series circuit. If we choose the phase of the current to be zero, the current can be written as

$$i_s = I \sin(\omega t) \quad (5)$$

Then the source voltage is

$$v_s = V \sin(\omega t + \phi) \quad (6)$$

where the source voltage leads the current by the phase angle

$$\phi = \tan^{-1} \left(\frac{\omega L - 1/\omega C}{R} \right) \quad (7)$$

The phase angle can be illustrated by the vector representation in Figure 3. In this example the inductive reactance $X_L = \omega L$ is greater than the capacitive reactance $X_C = 1/\omega C$, thus, the phase angle is positive and the source voltage leads the source current. For a constant amplitude source

$$I = \frac{V}{Z} \quad (8)$$

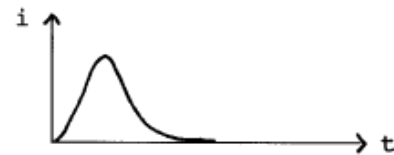
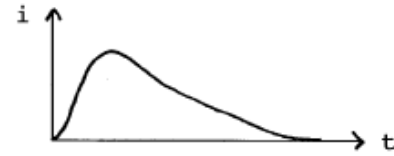

Figure 2: Underdamped, Overdamped, and Critically Damped LRC Circuit Response

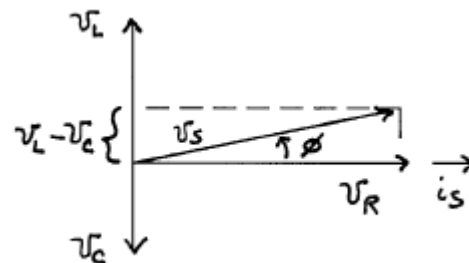

Figure 3 Phase Relationships

Experiment 8, RLC Resonant Circuits

where the impedance Z is given by

$$Z = \sqrt{R^2 + (\omega L - 1/\omega C)^2} \quad (9)$$

The important difference between the LRC circuit and that of either the RC or RL circuits is that the current does not asymptotically increase or decrease but has a maximum. Note the behavior of the impedance

$$Z \rightarrow \begin{cases} \infty & \text{as } \omega \rightarrow 0 \\ \infty & \text{as } \omega \rightarrow \infty \end{cases} \quad (10)$$

Note that the current goes to zero when the impedance becomes infinite. Thus, the current is zero for zero frequency, peaks for some finite frequency, and then drops to zero for large frequencies. The current reaches a maximum when the impedance is a minimum, or equivalently, for that frequency where the capacitive and inductive reactances are equal; i.e., from equation 9

$$\omega_o L - \frac{1}{\omega_o C} = 0 \quad \Rightarrow \quad \omega_o = \frac{1}{\sqrt{LC}} \quad (11)$$

This type of circuit is a selective filter and is the basis for tuning in radios and TVs, etc. A measure of how sharp the resonance peak is, or the fineness of tuning, is called the Q factor of the circuit. The Q value is defined as the inverse of the fractional bandwidth.

$$\frac{1}{Q} = \frac{\Delta\omega}{\omega_o} = \frac{\Delta f}{f_o} \quad (12)$$

In an LRC series circuit the Q value can be calculated for R not too large as

$$Q = \frac{\omega_o L}{R} \quad (13)$$

Part I: RC rehash

Re-build the low pass filter from lab 4 shown in Fig. 4

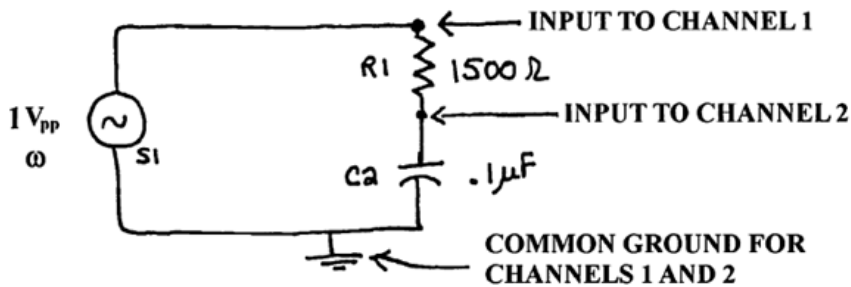

Figure 4: Low-pass RC filter

Sweep from low frequencies to high frequencies and observe how the output (Channel 2) depends on frequency. This is typical for a first order system. Estimate the cut-off frequency from what you see on the oscilloscope.

Part II: Ringing

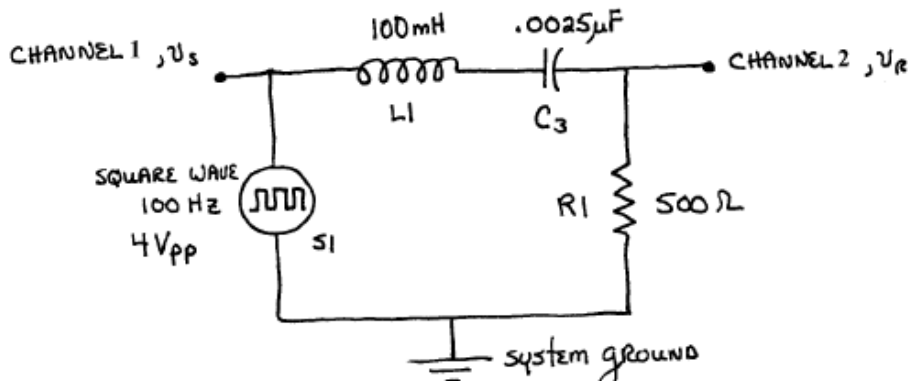

Figure 5: Laboratory Setup for Ringing

- Measure the resistance of the inductor L_1 with your multimeter.
- Construct the circuit shown above. This should produce an underdamped circuit.
- Using Eq. 4, calculate δ and the frequency of oscillation, f .
- Measure the actual frequency of oscillation from the scope on channel 2.
- Vary R and C around the given values.

Question 1: What are the most obvious effects of changing R at constant C ? How about changing C at constant R ? Consider Eqs. 4 when answering this question.

- For $L = 100 \text{ mH}$ and $R = 500 \Omega$, calculate the value of C needed to produce critical damping.
- Adjust C for critical damping on the oscilloscope (you won't find it unless you do the calculation in part f first).

Experiment 8, RLC Resonant Circuits

Question 2: Can you guess why there is a discrepancy between the actual C and the calculated C to produce critical damping?

Part III: Resonance

- Set up the following circuit to determine the resonance frequency of the circuit experimentally.

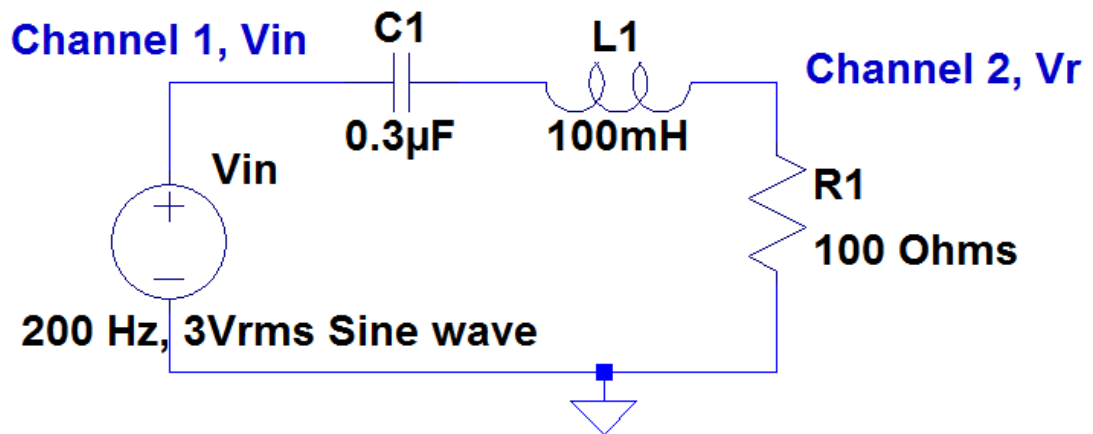

Figure 6 Series Resonance Circuit

Note: The 1.0Ω resistor is a current transducer, turning current into voltage by Ohms Law.

- Look for a resonance around 900 Hz. Remember to maintain the source voltage constant. The resonance is reached when V_R is a maximum. When you find resonance frequency, make many measurements around the resonance.
- Measure I_R as a function of frequency about the resonance.
- Plot I_R^2 versus frequency on the computer. This curve is proportional to power.
- Determine the resonance frequency f_0 and the bandwidth Δf from your plot.

Experiment 8, RLC Resonant Circuits

Name: _____

Part I:

Cut-off frequency

Part II:

$R_L =$

$\delta =$

$f(\delta) =$

$f_{\text{measured}} =$

Question 1:

$C_{\text{theory}} =$

$C_{\text{measured}} =$

Question 2:

Part III: (staple graph)

L =

R =

f(Hz)	i	i ²
200		
5000		
$f_0 =$	$\omega_0 =$	